

MXZ-HA R32

Multi-Split Outdoor Units

Inverter Heat Pump (4-5kW)

Mseries

The **MXZ-HA** range of multi-split outdoor units connects to our MSZ-HR classic wall mounted indoor units. Together they form exceptional value small multi-split systems that can be used in a wide range of applications such as residential spaces, small offices and light commercial premises.

R32

Key Features & Benefits:

- 2 or 3 indoor units can be connected to a single outdoor unit
- Available in 4 or 5kW capacities
- 30-50m total system piping length
- MSZ-HR connection only



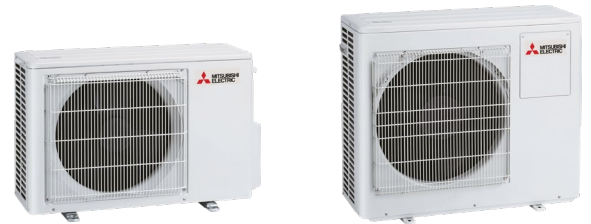

MXZ-HA OUTDOOR UNITS		MXZ-2HA40VF	MXZ-2HA50VF	MXZ-3HA50VF
NUMBER OF CONNECTABLE INDOOR UNITS		2	2	2 - 3
CAPACITY (kW)	Heating (nominal)	4.3 (1.0 - 4.7)	6.0 (1.0 - 6.4)	6.0 (2.6 - 7.5)
	Cooling (nominal)	4.0 (1.1 - 4.3)	5.0 (1.1 - 5.4)	5.0 (2.9 - 6.5)
	Heating (UK)	3.61 (0.84 - 3.95)	5.04 (0.84 - 5.38)	5.04 (2.18 - 6.30)
	Cooling (UK)	4.00 (1.10 - 4.30)	5.00 (1.10 - 5.40)	4.50 (2.61 - 5.85)
COP / EER (nominal)	4.73 / 3.81	3.90 / 3.29	4.62 / 3.97	
SCOP (η _{sh}) / SEER (η _{sc}) (BS EN14825)	4.30 / 8.12	4.30 / 7.78	4.02 / 7.26	
ErP ENERGY EFFICIENCY CLASS	Heating / Cooling	A+ / A++	A+ / A++	A+ / A++
MAX AIRFLOW (m ³ /min)	Heating / Cooling	33.5 / 28.4	34.7 / 32.7	29.1 / 31.0
SOUND PRESSURE LEVEL (dBA)	Heating/Cooling	50 / 44	51 / 47	50 / 46
SOUND POWER LEVEL (dBA)	Cooling	59	64	61
DIMENSIONS (mm)	Width x Depth x Height	800 x 285 x 550	800 x 285 x 550	840 x 330 x 710
WEIGHT (kg)		37	37	57
ELECTRICAL SUPPLY		220-240V, 50Hz	220-240V, 50Hz	220-240V, 50Hz
PHASE		Single	Single	Single
POWER INPUT (kW)	Heating/Cooling (nominal)	0.91 / 1.05	1.54 / 1.52	1.30 / 1.26
	Heating/Cooling (UK)	0.82 / 0.90	1.39 / 1.31	1.17 / 1.08
STARTING CURRENT (A)		7.6	7.6	6.7
RUNNING CURRENT (A)	Heating/Cooling [MAX]	4.4 / 4.7 [12.2]	6.6 / 6.5 [12.2]	5.6 / 5.4 [18.0]
INTERCONNECTING CABLE No. CORES		4 Core	4 Core	4 Core
TOTAL PIPE LENGTH (m)		30	30	50
MAX PIPE LENGTH PER INDOOR UNIT (m)		20	20	25
MAX HEIGHT DIFFERENCE (m)		15 (10 if OU higher than IU)	15 (10 if OU higher than IU)	15 (10 if OU higher than IU)
CHARGE REFRIGERANT (kg) / CO ₂ EQUIVALENT (t)	R32 (GWP 675)	0.9 / 0.61	0.9 / 0.61	1.4 / 0.95
MAX ADDITIONAL REFRIGERANT (kg) / CO ₂ EQUIVALENT (t)	R32 (GWP 675)	0	0	0.2 / 0.14
FUSE RATING (BS88) - HRC (A)		16	16	20

Note: MSZ-HR connection only.

MXZ-2HA40/50VF DIMENSIONS

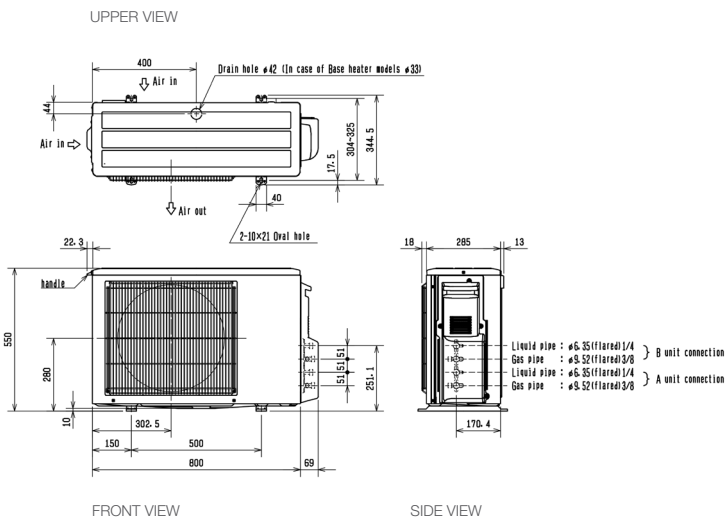

MXZ-3HA50VF DIMENSIONS

